

- **Lite-Lift®** Effortless Chain Mechanism
- **Gline Chain Operated Shades Feature Lite-Lift®** a smooth state of the art easy lift activated mechanism.
- **Lite-Lift®** provides a smooth constant effortless lift of all shades with finger tip control.
- **Lite-Lift®** alleviates stress on the chain and avoids chain breakage (Major cause of maintenance associated with chain operated shades).
- **Shade can be pulled down by the bottom bar** (without stripping or damaging the mechanism) without having to pull from the chain.

Shade mechanism cannot be stripped or damaged!

Virtually lasts forever. **Durable - Heavy use design**, important in commercial applications where products are subject to abuse.

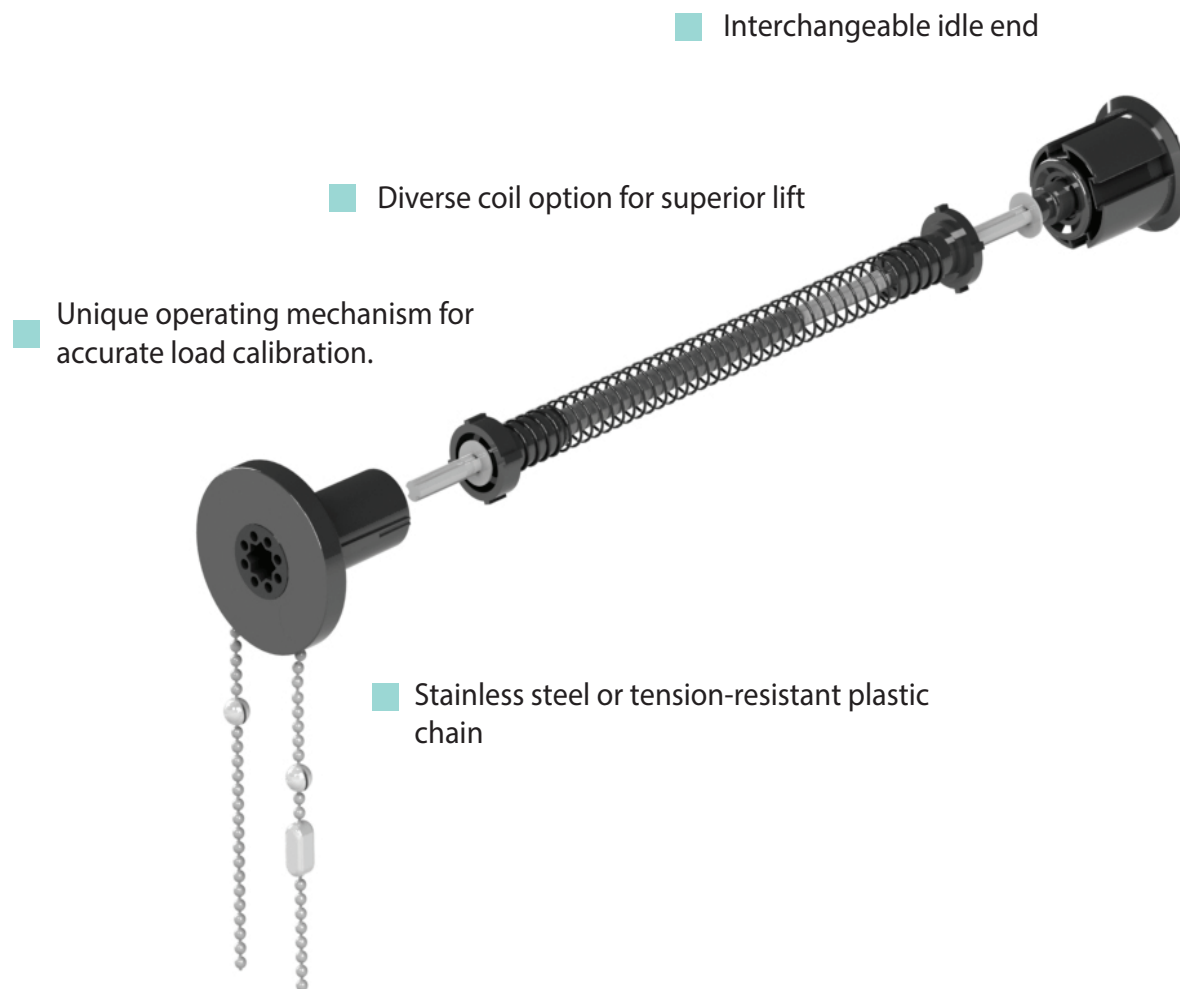

MANUAL ROLLER SHADES - CHAIN OPERATED

■ SLIM LINE **OPEN ROLL** (MOD. OR-45)

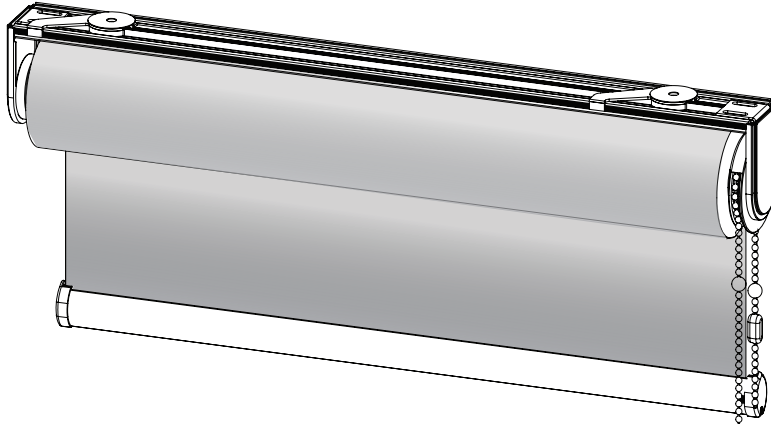

■ SLIM LINE **CASSETTE** (MOD. DK-70)

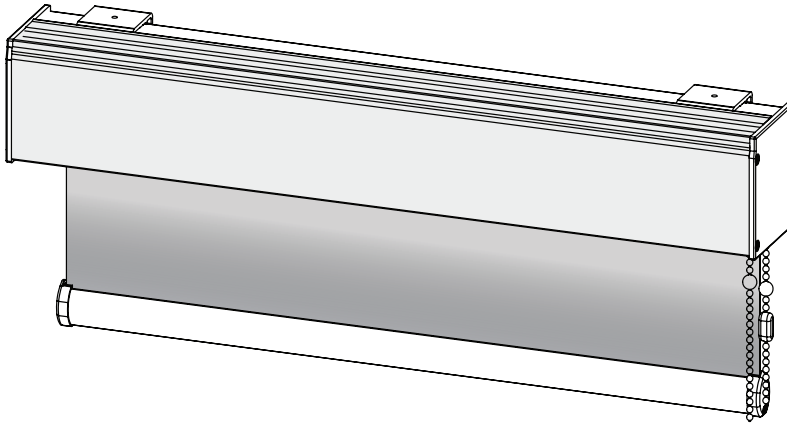

■ SLIM LINE **CASSETTE** (MOD. TK-70)

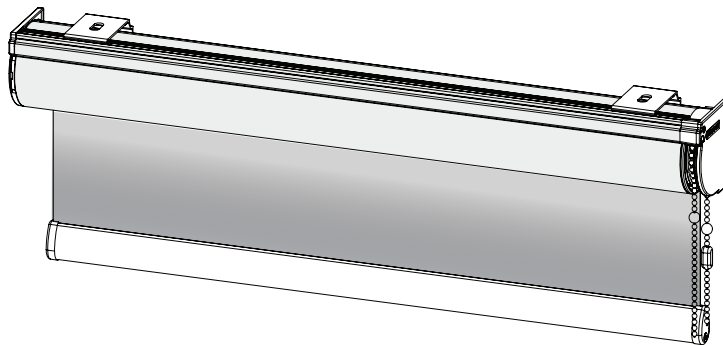

MANUAL ROLLER SHADES - CHAIN OPERATED

■ SINGLE SHADE

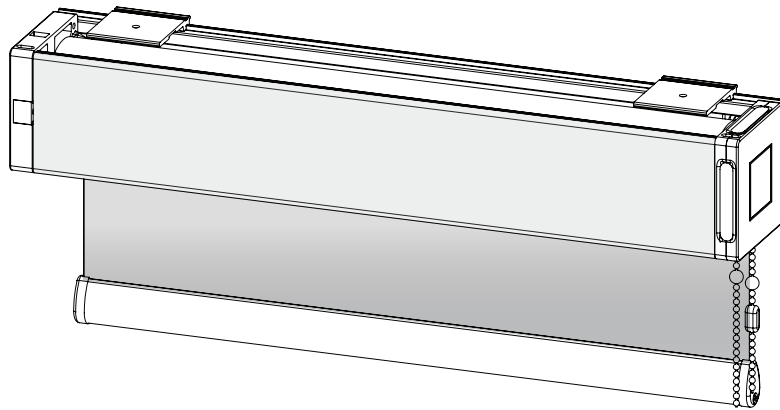

■ TANDEM SHADE

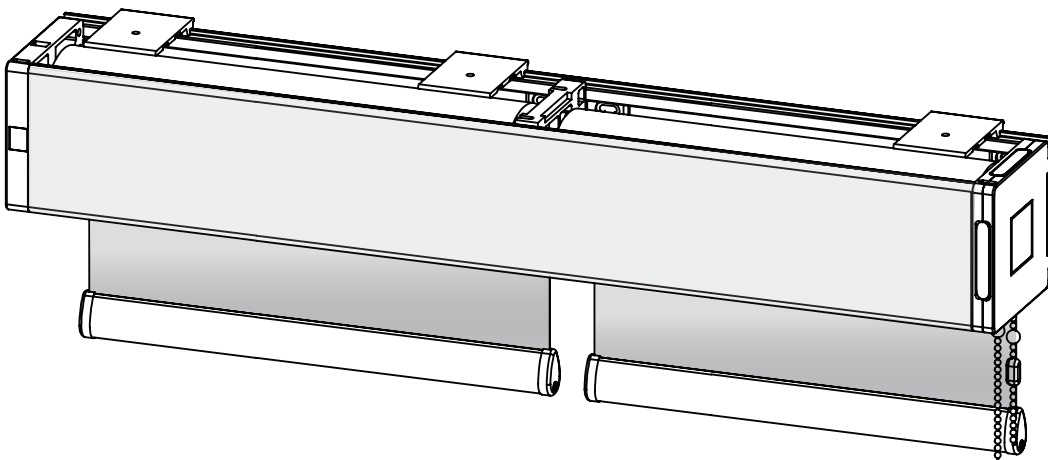

AVAILABLE IN: 2B 3B

SIZE LIMITATIONS APPLIES. CALL G-LINE FOR DETAILS

MANUAL ROLLER SHADES - CHAIN OPERATED
AVAILABLE TANDEM OPTIONS

SINGLE SHADE

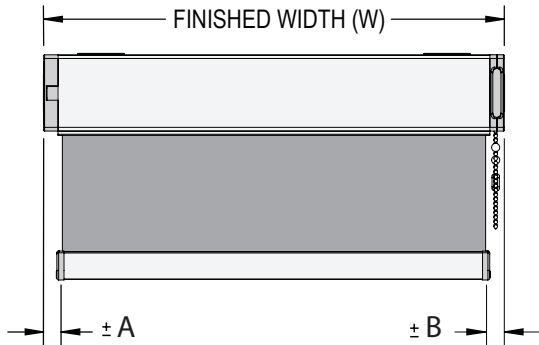

2 BANDED TANDEM SHADE

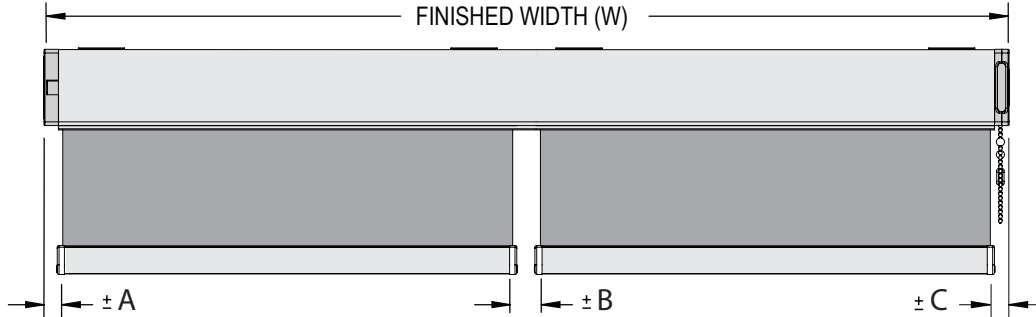

3 BANDED TANDEM SHADE

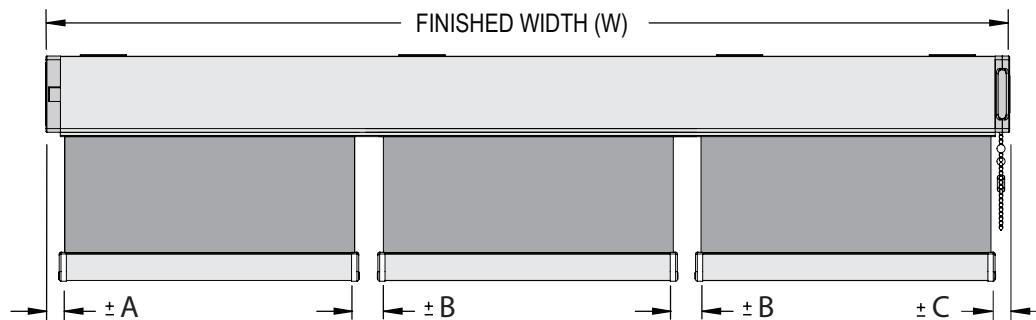

EDGE CLEARANCE	A	B	C
DIMENSION	± 22 [0.875"]	± 44 [1.732"]	± 22 [0.875"]

MANUAL ROLLER SHADES - CHAIN OPERATED

■ SINGLE SHADE

