

AUTOMATED ROLLER SHADES - 120VAC DRIVE

SINGLE SHADE

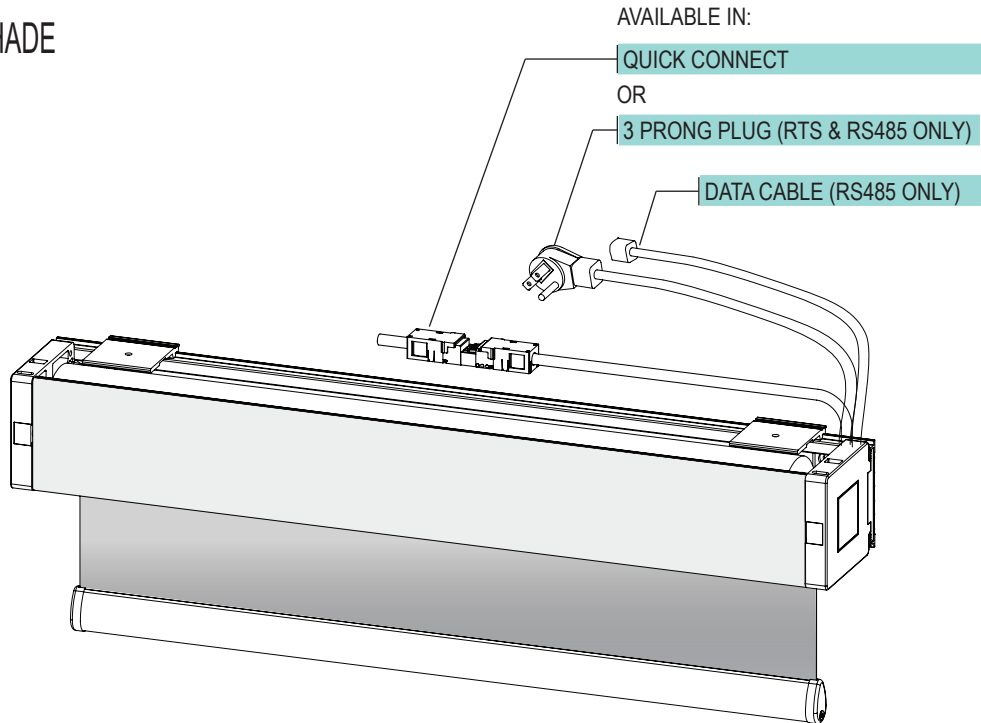

TANDEM SHADE

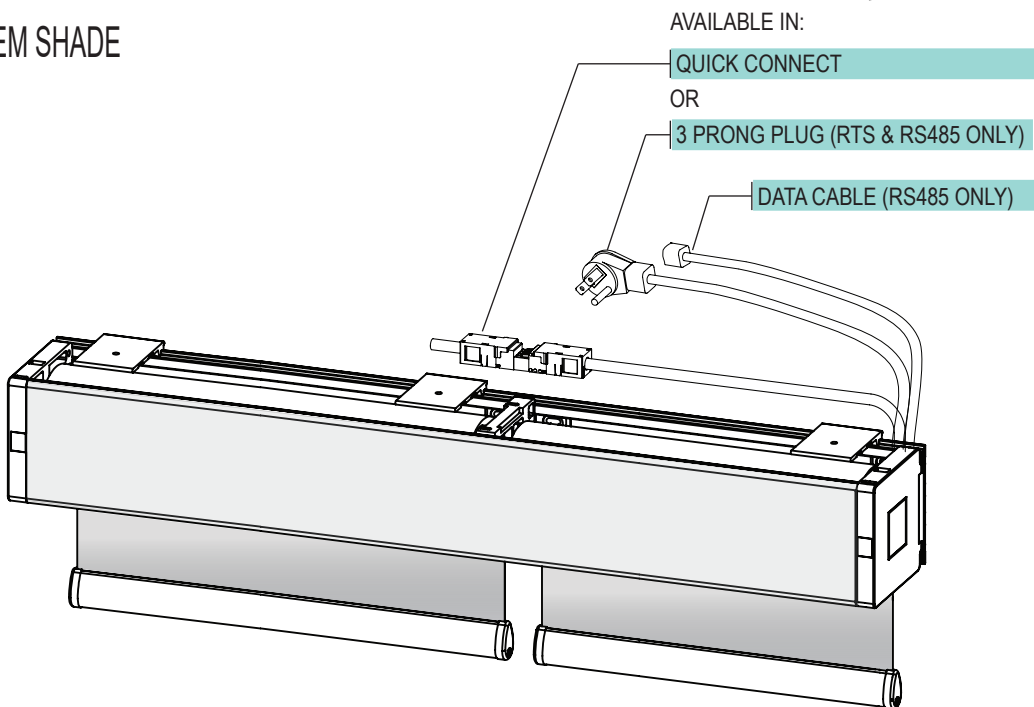

AVAILABLE IN: 2B 3B 4B

SIZE LIMITATIONS APPLIES. CALL G-LINE FOR DETAILS

AUTOMATED ROLLER SHADES - 120VAC DRIVE

■ SINGLE SHADE

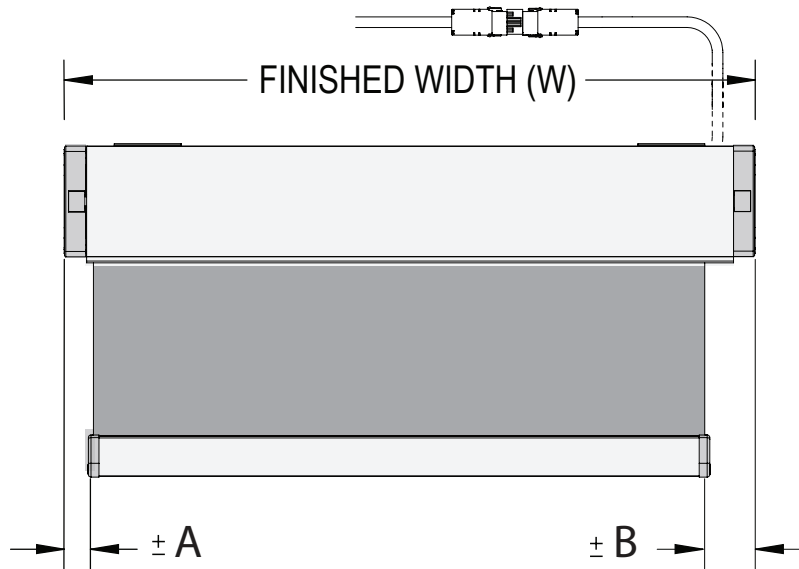

SIZE LIMITATIONS APPLIES. CALL G-LINE FOR DETAILS

| EDGE CLEARANCE | A | B |
|----------------|---------------|---------------|
| DIMENSION | ± 22 [0.875"] | ± 38 [1.500"] |

AUTOMATED ROLLER SHADES - 120VAC DRIVE
AVAILABLE TANDEM OPTIONS

2 BANDED TANDEM SHADE

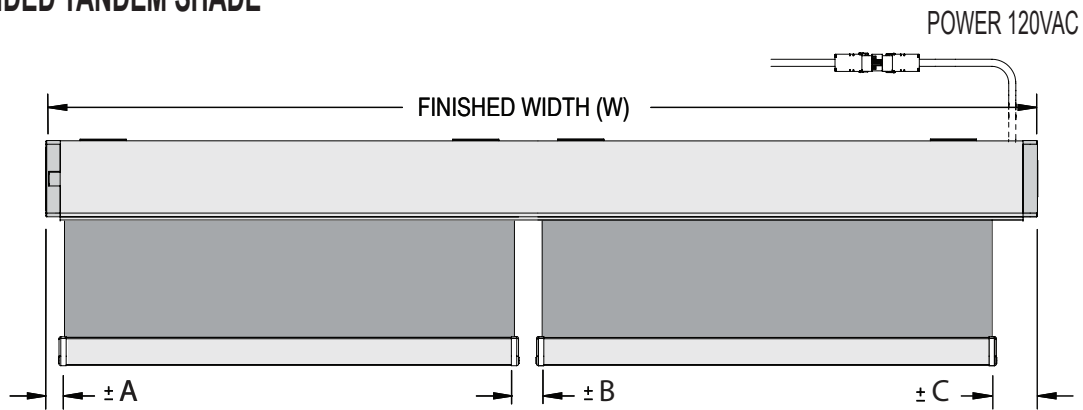

3 BANDED TANDEM SHADE

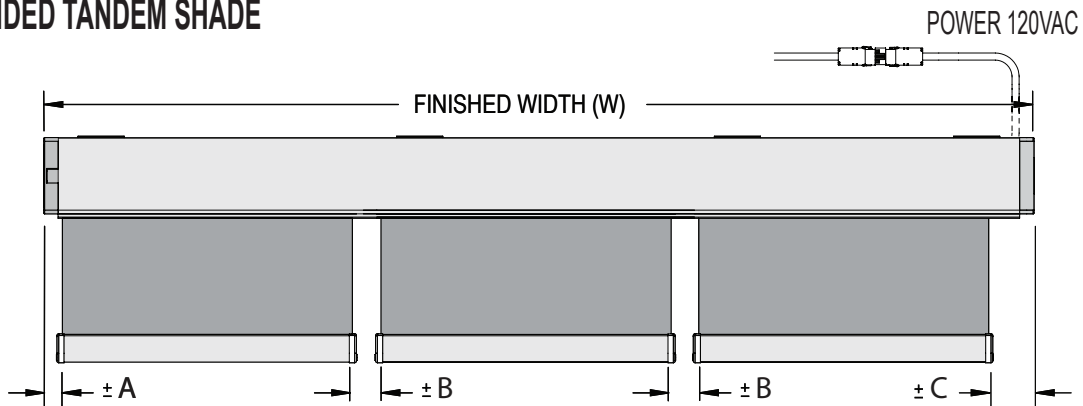

4 BANDED TANDEM SHADE

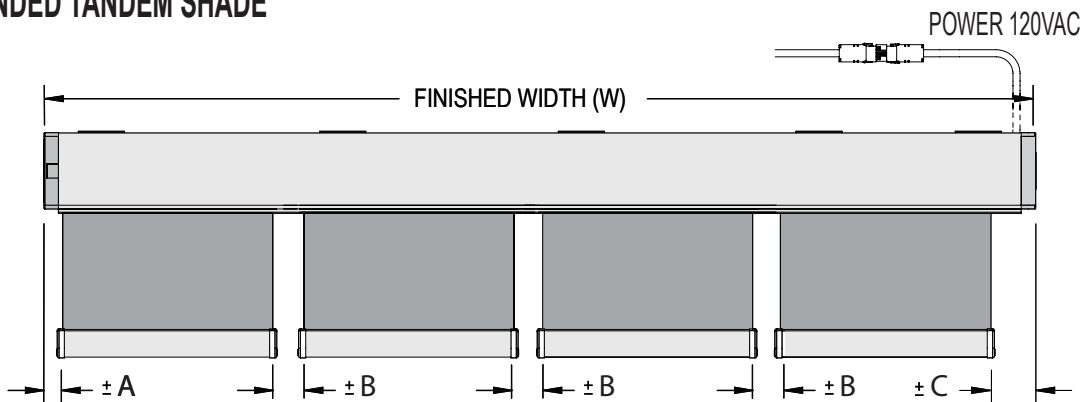

| EDGE CLEARANCE | A | B | C |
|----------------|-------------------|-------------------|-------------------|
| DIMENSION | ± 22 [0.875"] | ± 44 [1.732"] | ± 38 [1.500"] |

AUTOMATED ROLLER SHADES - 120VAC DRIVE

SINGLE SHADE

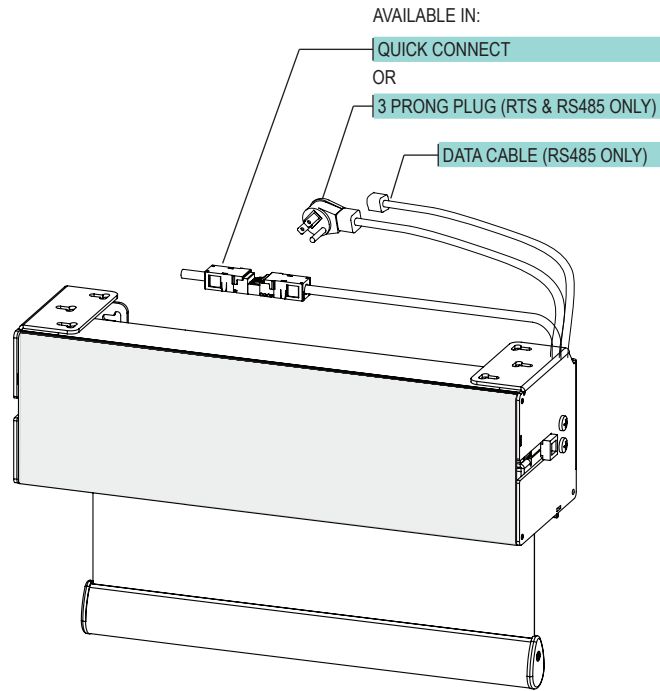

TANDEM SHADE

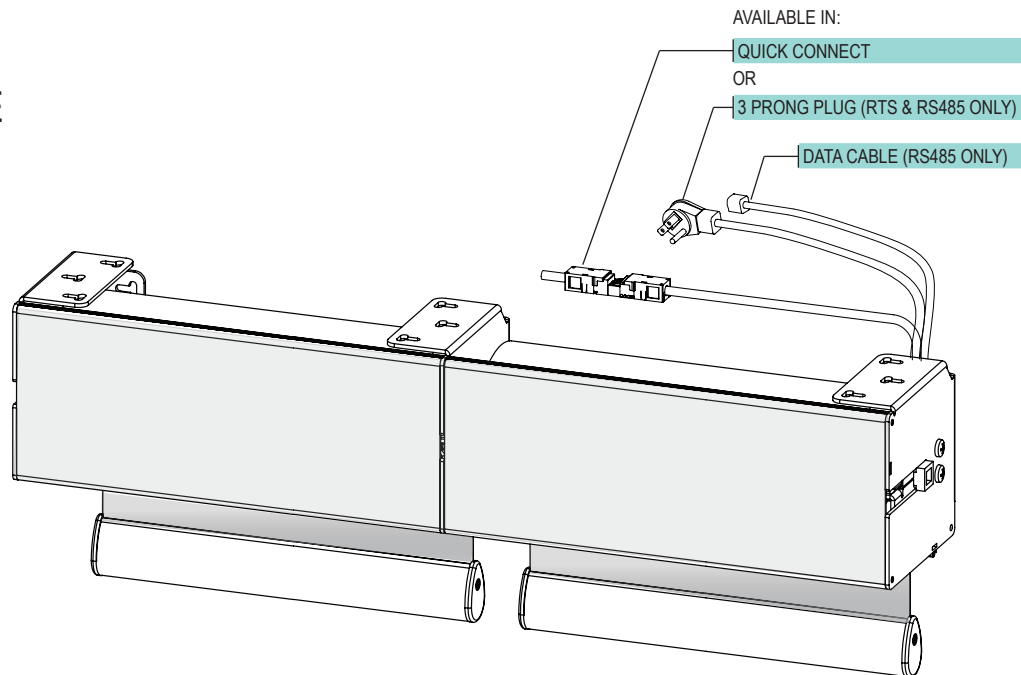

AVAILABLE IN: 2B 3B 4B SIZE LIMITATIONS APPLIES. CALL G-LINE FOR DETAILS

AUTOMATED ROLLER SHADES - 120VAC DRIVE

■ SINGLE SHADE

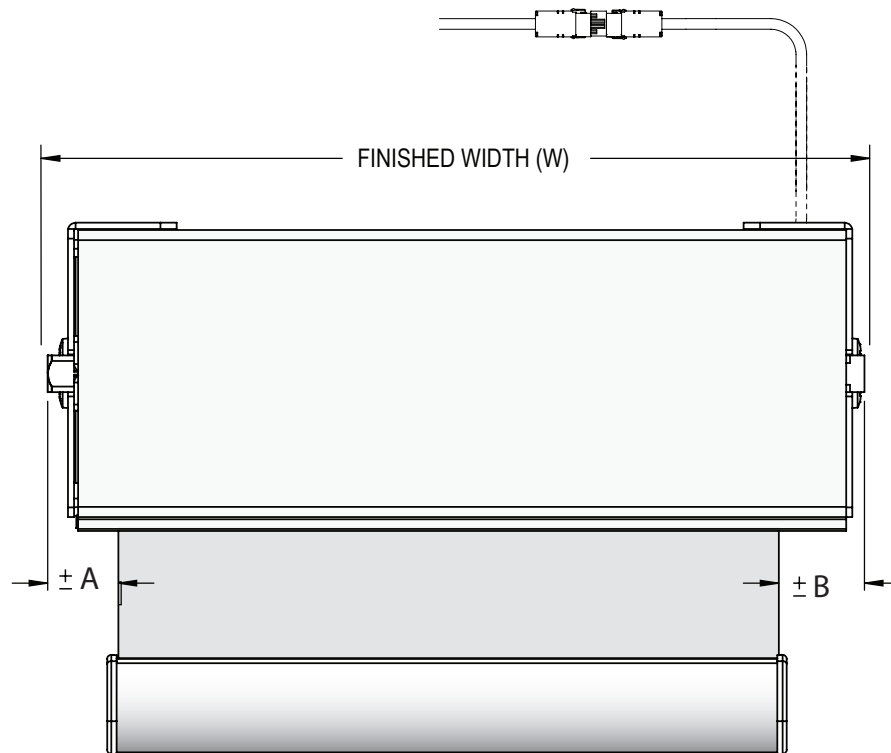

SIZE LIMITATIONS APPLIES. CALL G-LINE FOR DETAILS

| EDGE CLEARANCE | A | B |
|----------------|----------------|---------------|
| DIMENSION | ± 34 [0.1357"] | ± 42 [1.644"] |

AUTOMATED ROLLER SHADES - 120VAC DRIVE

2 BANDED TANDEM SHADE AVAILABLE TANDEM OPTIONS

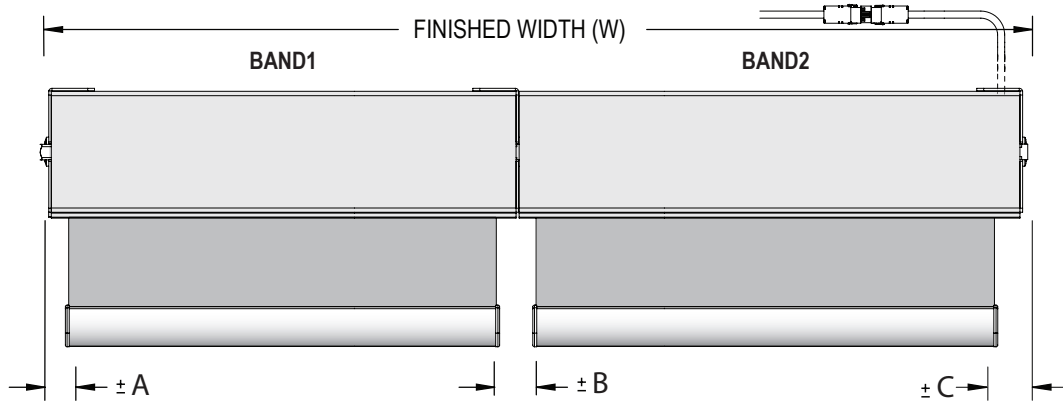

3 BANDED TANDEM SHADE

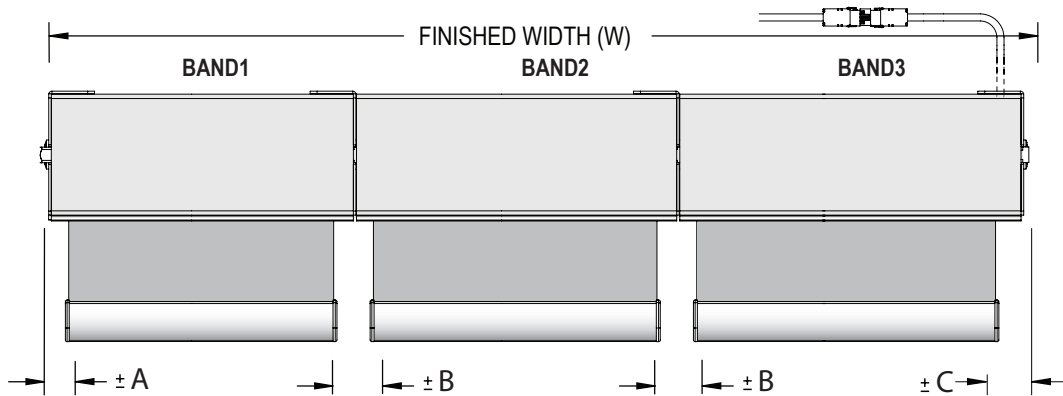

4 BANDED TANDEM SHADE

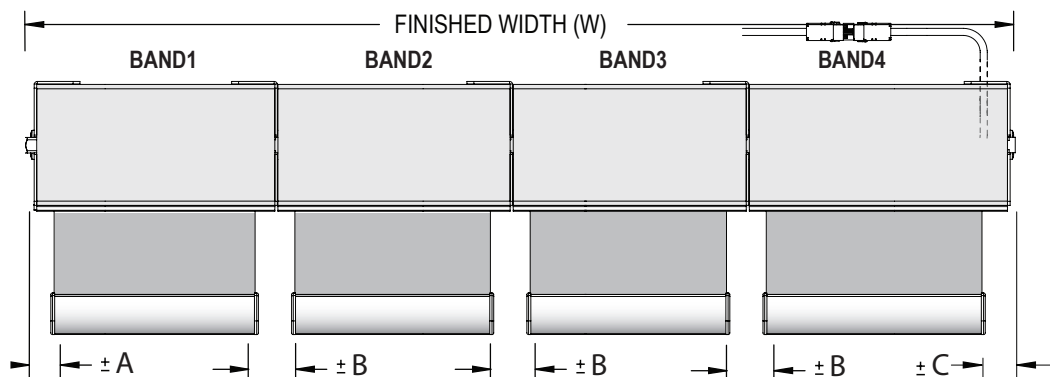

| EDGE CLEARANCE | A | B | C |
|----------------|--------------|--------------|--------------|
| DIMENSION | ±34 [1.357"] | ±56 [2.204"] | ±42 [1.654"] |