

## AUTOMATED ROLLER SHADES-120VAC DRIVE

### SINGLE SHADE

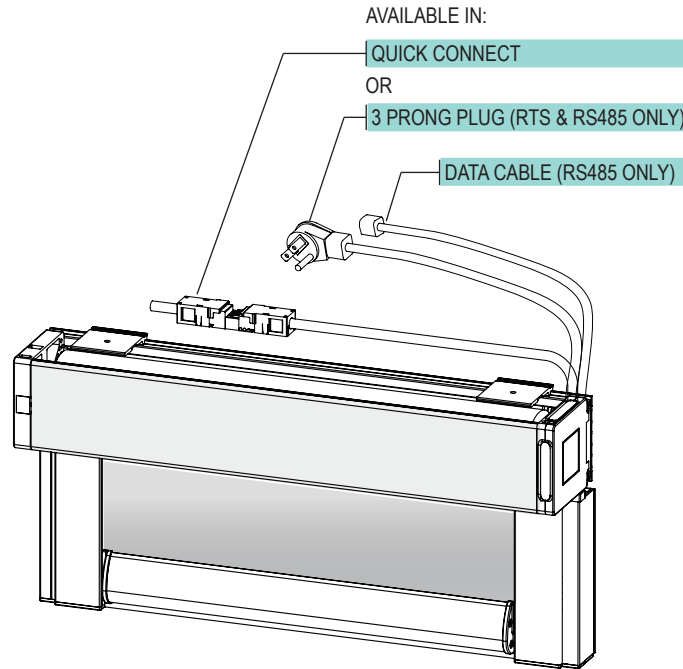

### TANDEM SHADE

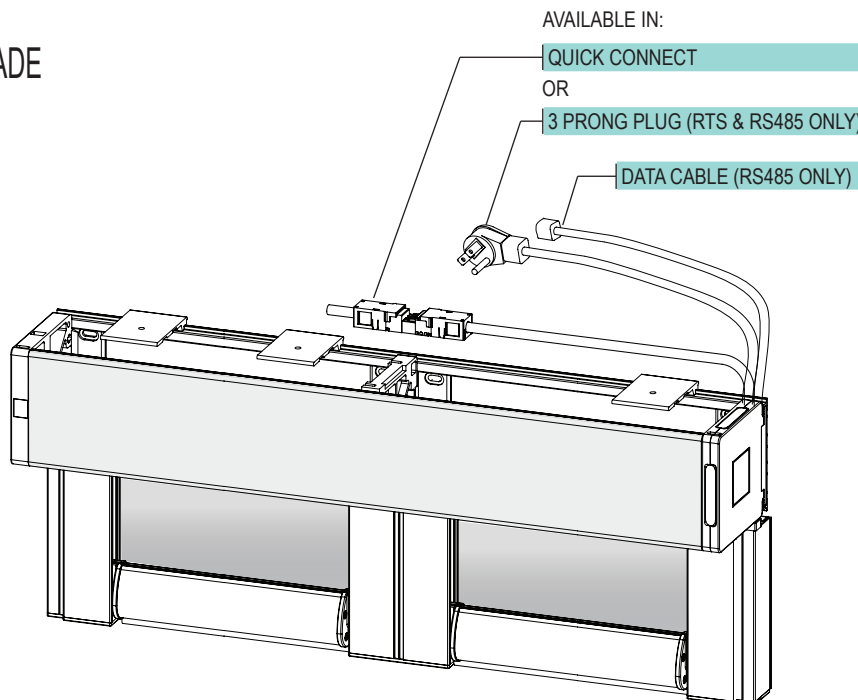

AVAILABLE IN: **2B** **3B** SIZE LIMITATIONS APPLIES. CALL G-LINE FOR DETAILS

**AUTOMATED ROLLER SHADES-120VAC DRIVE**  
AVAILABE TANDEM OPTIONS

**2 BANDED TANDEM SHADE**

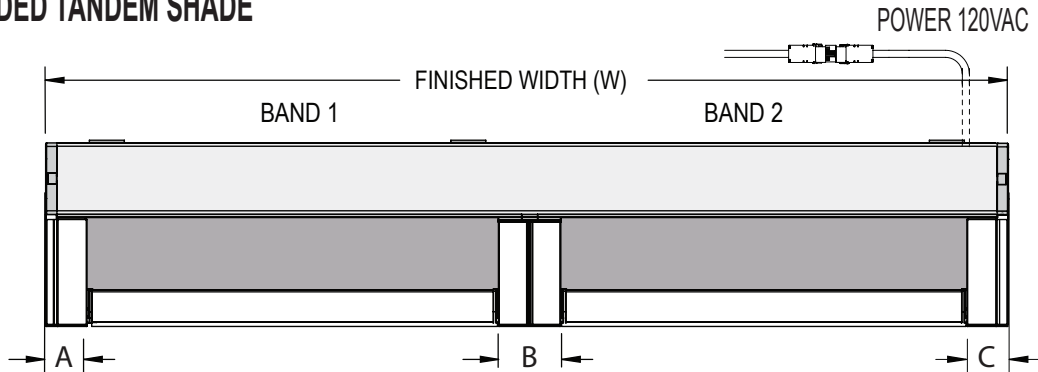

**3 BANDED TANDEM SHADE**

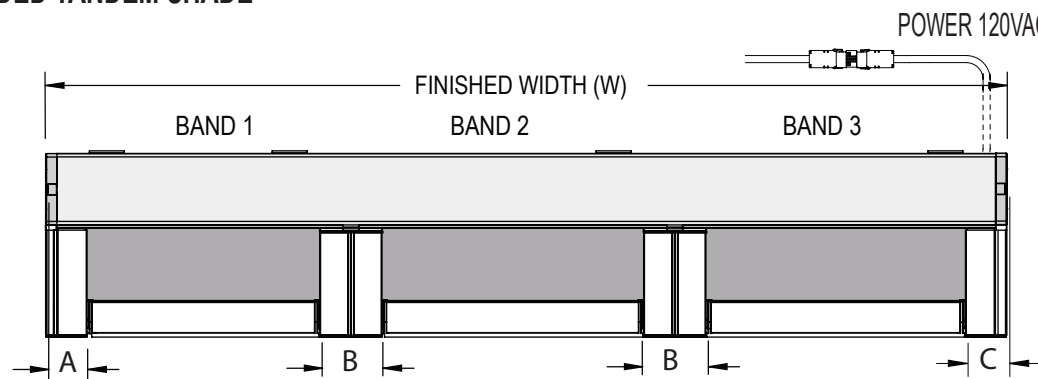

**4 BANDED TANDEM SHADE**

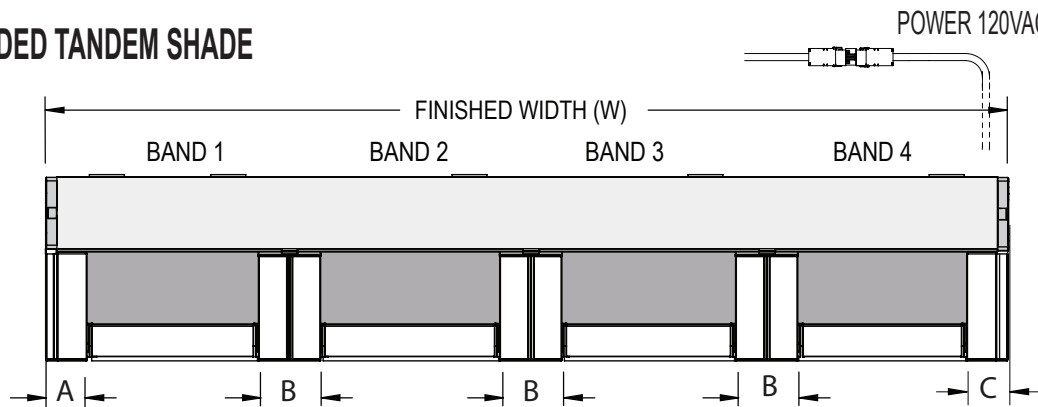

CHANNEL	A	B	C
	T-460	T-490	T-460
	± 60 [2.362"]	± 90 [3.543"]	± 60 [2.362"]
DIMENSION			

**AUTOMATED ROLLER SHADES-120VAC DRIVE**

**SINGLE SHADE**

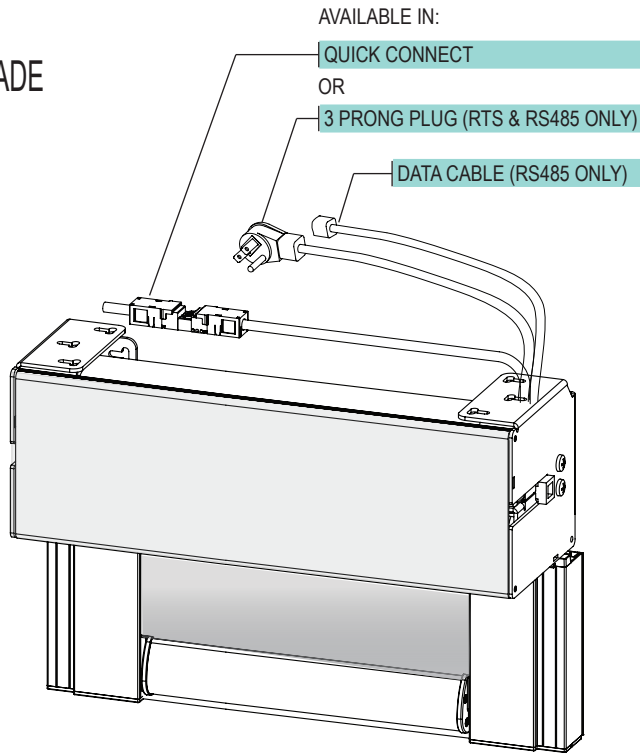

**TANDEM SHADE**

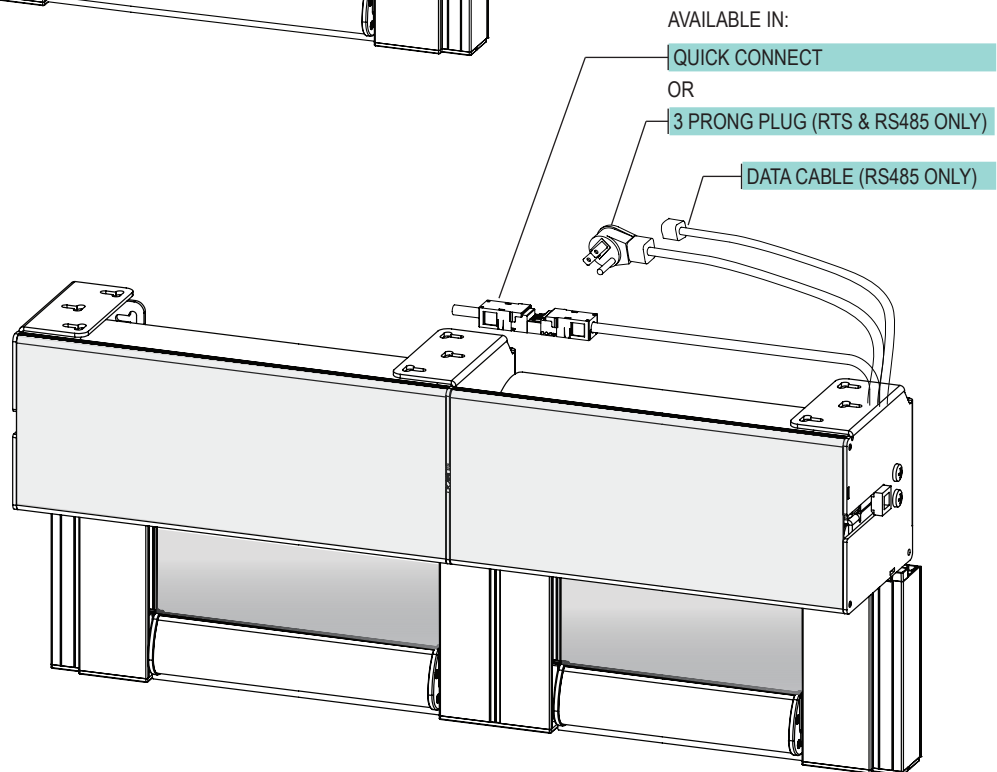

AVAILABLE IN: 2B 3B 4B

SIZE LIMITATIONS APPLIES. CALL G-LINE FOR DETAILS

**AUTOMATED ROLLER SHADES-120VAC DRIVE**  
AVAILABLE TANDEM OPTIONS

**2 BANDED TANDEM SHADE**

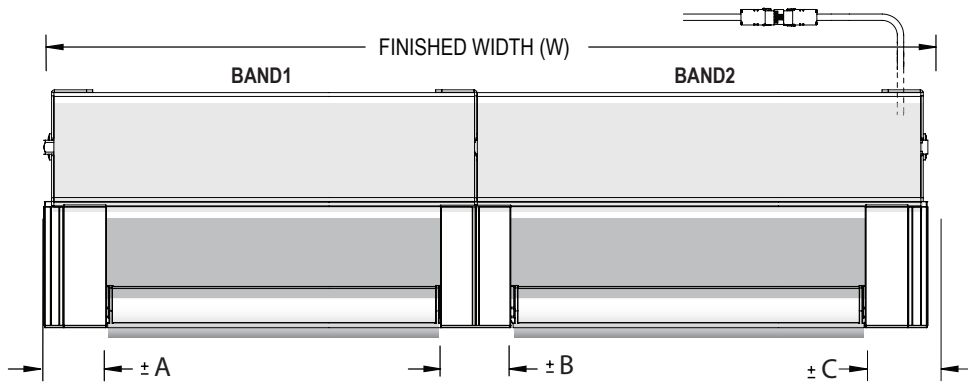

**3 BANDED TANDEM SHADE**

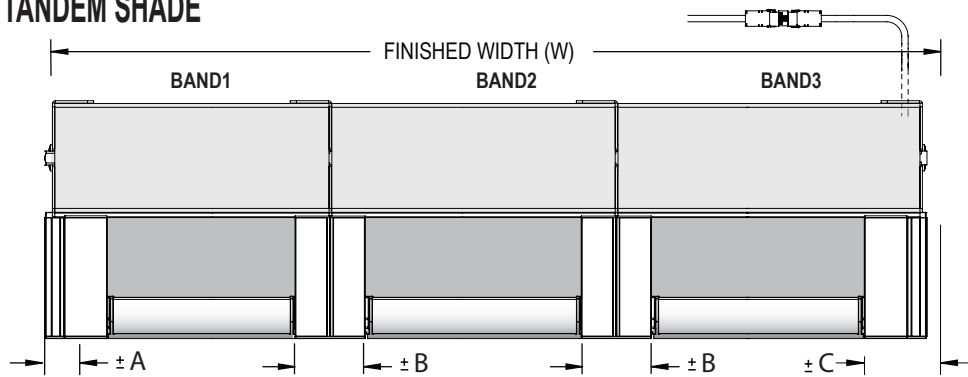

**4 BANDED TANDEM SHADE**

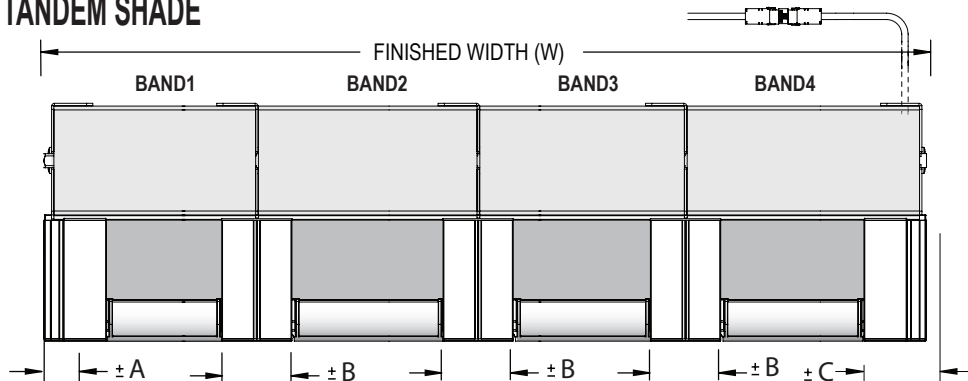

CHANNEL	A	B	C
	T-480	T-490	T-480
	± 81 [3.174"]	± 90 [3.543"]	± 81 [3.174"]

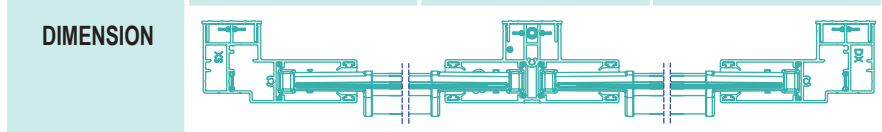

AVAILABLE IN: 2B 3B 4B